

BIO-HYDROMECHANICAL INTERCEPTOR AG1.5

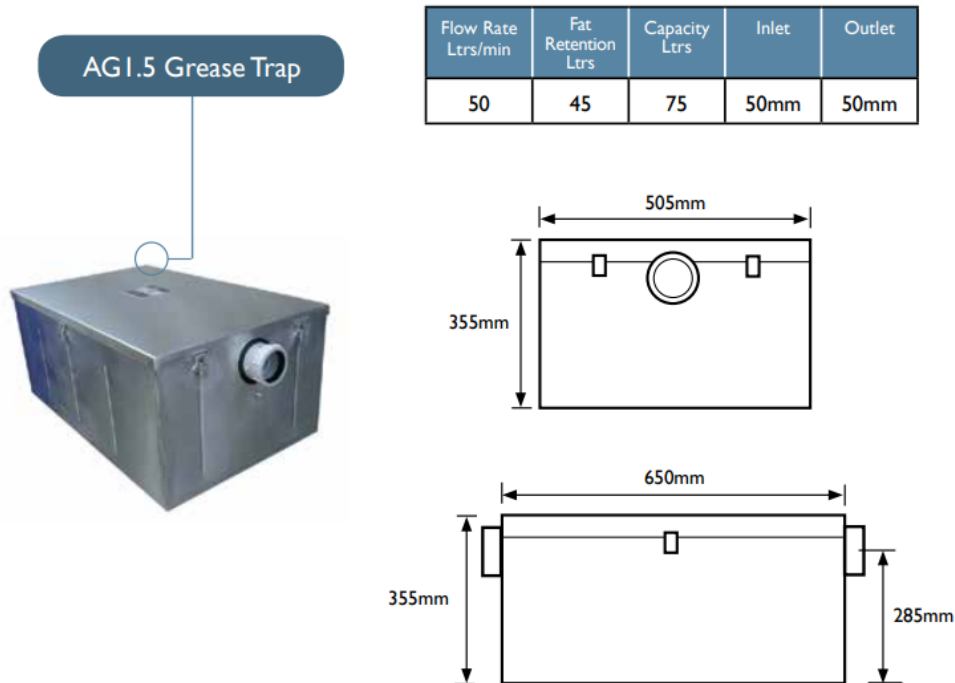

AG1.5 – Designed for use where space is constricted

Requires frequent cleaning due to small volume!

Would benefit if sink is fitted with Sink Guard filter

Fitted with filter basket for solid retention

Clips that fasten lid must be accessible

Bio-Dosing can be with DN6 Pump / Devastator

Standard inlet/outlet 50mm fit reducer for 40mm connection

Contacts

E-mail: enquiry@alulinegroup.com

Website: [Welcome To Aluline Ltd : Aluline Ltd \(alulinegms.com\)](http://alulinegroup.com)

Num: 004401928563532



This is copyright & design protected